



Residential Tankless Water Heaters



GSW powered by Takagi offers tankless products to match the needs of today's average household.

State-of-the-art residential tankless water heaters, including a condensing model, are all ENERGY STAR® qualified and provide an Energy Factor (EF) up to 0.95.

GSW powered by Takagi is your solution for endless hot water.

PRODUCT FEATURES:

- ENERGY STAR® qualified
- Technology to meet today's demands
 - Growing demands throughout the home require a consistent, never-ending supply of hot water
- Energy Savings
 - Plenty of hot water delivered in the most energy-efficient way possible
 - Up to 0.95 Energy Factor
- Eco-conscious
 - Use less energy: more energy savings compared to standard water heater
 - Efficient use of hot water
- Serviceability
 - Easy diagnostics and troubleshooting
 - Condensing models feature built-in numerical digital display
 - Non-condensing models include temperature remote controller with numerical digital display
- Limited 15-Year Residential Heat Exchanger Warranty



GSWT-540H-DV
Condensing Model Shown





GSWT-540H-DV 5.4 GPM at 70°F Temperature Rise

Installation Type	Direct Vent	
Dimensions	22 1/2" (H) x 17 3/4" (W) x 10 3/4" (D), Weight: 59 lbs	
Electric Consumption	120 VAC 0.74A (Operation) 0.04 A (Standby) 1.5 A (Freeze-Protection)	
Ignition	Electronic Ignition	
Fuel	NG	LP
Gas Input	Min 15,000 BTU/h Max 199,000 BTU/h	Min 13,000 BTU/h Max 199,000 BTU/h
Energy Factor	0.95	0.95
Gas Pressure	Min. 5.0" W.C. Min. 10.5" W.C.	Min. 8.0" W.C. Min. 14.0" W.C.
Maximum Flow Rate	Max 10.0 GPM at 30°F Temperature Rise	
Water Pressure	15-150 psi	Pressure-only relief valve required (min. 200,000 BTU/h, 150 psi). 40 psi or above recommended for maximum flow.
Multiple Unit Installation	Easy-Link System UP TO 4 UNITS (with no additional parts/accessories required) Multi Unit UP TO 20 UNITS (with TM-MC02 controller)	
Temperature Settings	100°F, 105°F, 110°F, 115°F, 120°F (default), 125°F, 130°F, 135°F, 140°F, 145°F, 150°F, 155°F, 160°F, 165°F, 175°F, 185°F (16 settings)	
Warranty	Residential 15 years Heat Exchanger, 5 years Parts Commercial 10 years Heat Exchanger, 5 year Parts	

Product Features

- Condensing technology
- Unprecedented 0.95 Energy Factor
- Durable Heat Exchanger: Uses HRS35 copper for primary heat exchanger and Stainless Steel #316L for secondary heat exchanger
- Approved with ULC s636 PVC or CPVC or polypropylene venting in addition to Cat. III/IV Stainless Steel
- Vent with 3" (up to 70 feet) or 4" (up to 100 feet)
- 0" Clearance to combustibles
- Integrated control and diagnostics
- Air Fuel Ratio (AFR) Sensor
- Factory-installed power cord
- Dual internal freeze-protection system
- High altitude installations (up to 10,000 ft.)

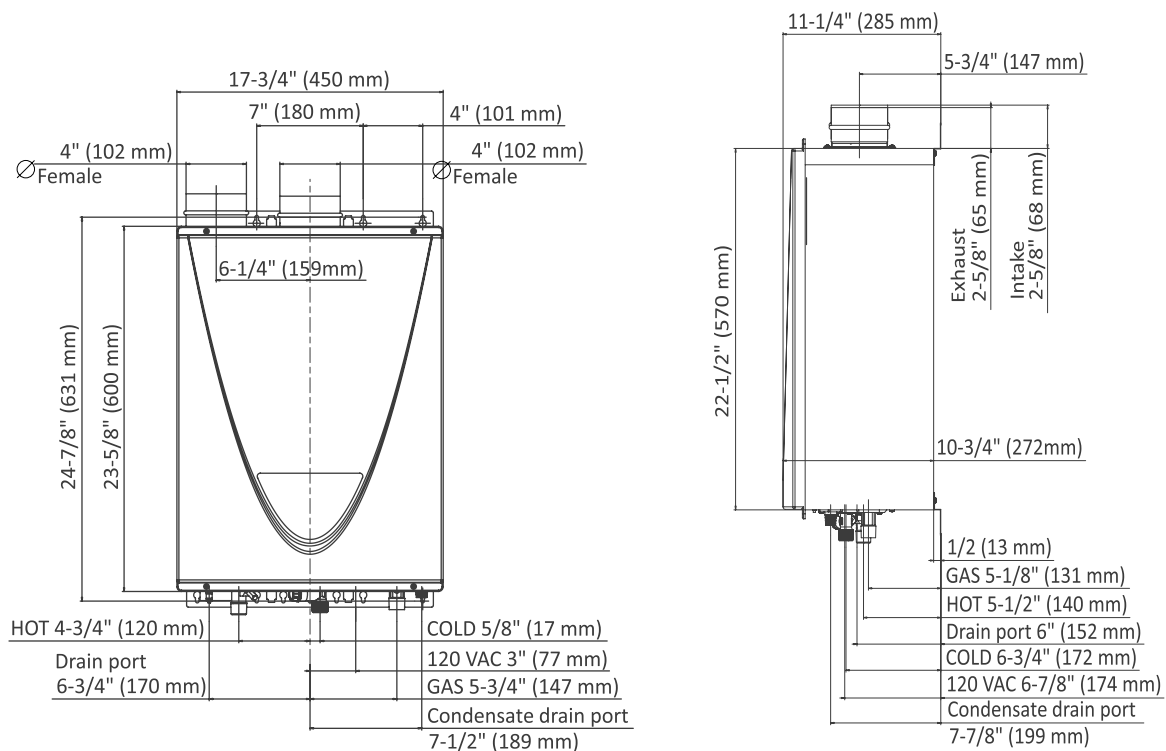

GSWT-310 4.3 GPM at 70° temperature rise



Installation Type	Power Vent (Direct Vent Convertible with TK-TV10)		
Dimensions	20 1/4" (H) x 13 3/4" (W) x 8 1/2" (D), Weight: 38 lbs		
Electric Consumption	120 VAC	0.73A (Operation)	0.05 A (Standby) 0.93 A (Freeze-Protection)
Ignition	Electronic Ignition		
Fuel	NG		LP
Gas Input	Min 11,000 BTU/h		Min 11,000 BTU/h
	Max 190,000 BTU/h		Max 190,000 BTU/h
Energy Factor	0.82		0.82
Gas Pressure	Min. 5.0"W.C.		Min. 8.0"W.C.
	Max. 10.5"W.C.		Max. 14.0"W.C.
Maximum Flow Rate	Max 8.0 GPM at 30°F Temperature Rise		
Water Pressure	15-150 psi	Pressure-only relief valve required (min. 200,000 BTU/h, 150 psi). 40 psi or above recommended for maximum flow.	
Temperature Settings	Dipswitch Settings	113°F, 122°F(default), 131°F, 140°F	
	With TK-RE02 Temperature Remote Controller INCLUDED: 99°F to 167°F, 122°F Default Factory Setting 99°F, 100°F, 102°F, 104°F, 106°F, 108°F, 109°F, 111°F, 113°F, 115°F, 117°F, 122°F(default), 131°F, 140°F, 158°F, 167°F		
Warranty	Residential	15 years Heat Exchanger	5 years Parts



Product Features

- ENERGY STAR® qualified
- Power Vent design
- Safety Features: Air-Fuel Ratio (AFR) Sensor, Water Temperature Safety Device, Overheat Cutoff Fuse
- Fully modulating
- TK-RE02 temperature remote included
- Factory-installed power cord
- Vents with Cat. III stainless steel
- Built-in freeze protection

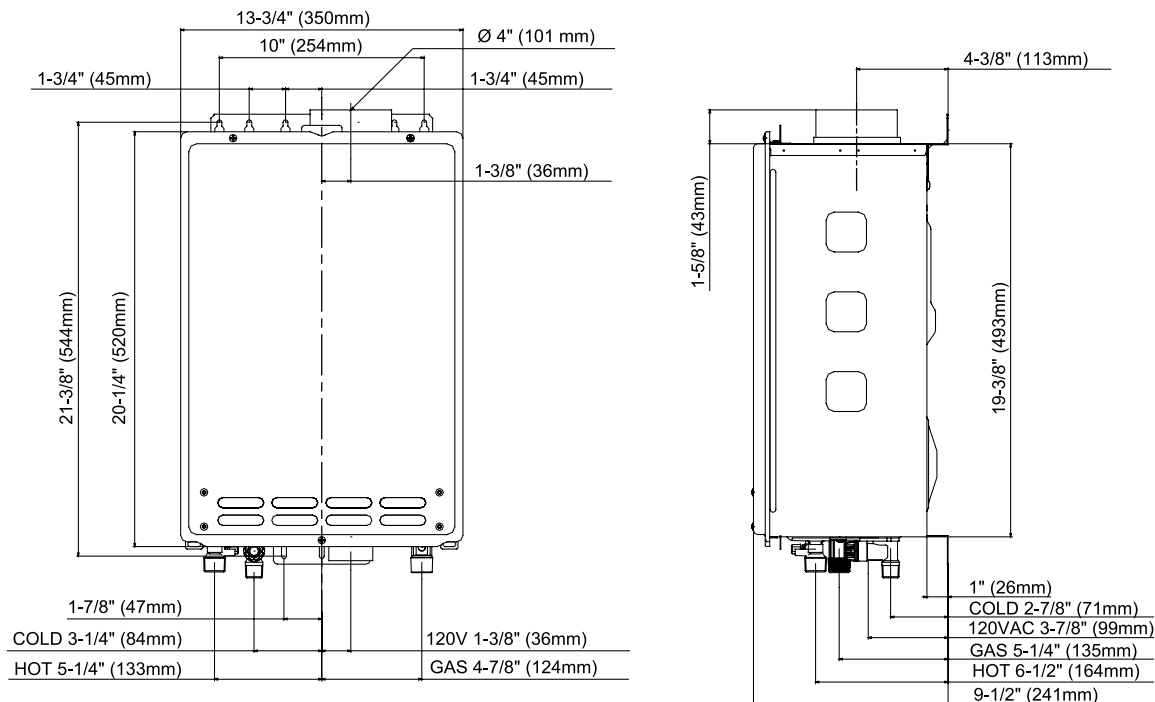



Residential Tankless Water Heaters



Residential Flow Rate Guide USG per minute

Temp Rise (°F)	GSWT-310	GSWT-540H-DV
30	8.0	10.0
35	8.0	10.0
40	7.8	9.5
45	6.9	8.4
50	6.2	7.6
55	5.7	6.9
60	5.2	6.3
65	4.8	5.8
70	4.3	5.4
75	4.1	5.0
80	3.9	4.7
85	3.7	4.4
90	3.5	4.2
95	3.3	4.0
100	3.1	3.8
105	n/a	3.7
110	n/a	3.4
115	n/a	3.2
120	n/a	3.1

Flow rate is determined by temperature rise. To determine your temperature rise, subtract the incoming water temperature from the set output temperature. All units are factory set at 120°F to 122°F but can be changed. Flow rates are based on default set temperatures. In Canada, base incoming water temperature for coldest climate on 40°F.

Match the unit to your needs

Number of showers each GSW powered by Takagi unit can handle, depending on inlet water temperature.

40°F Incoming Groundwater Temperature

Model	Capacity	Number of Shower Heads
GSWT-310	1 Shower	
GSWT-540H-DV	2 Showers	

Assuming the outgoing temperature is 120°F.

Assuming a standard shower head of max 2.5 GPM.

Accessories Chart

Compliment your GSW powered by Takagi tankless water heater with manufacturer recommended accessories

Description	Size	Part Number	GSWT-310	GSWT-540H-DV
Direct Vent Conversion Kit	3" diam.	TK-TV10	✓	
Concentric Vent Kit - Cat.III Stainless Steel Includes: 1 Backflow Adaptor/Drain Tee, 12" Straight Vent Pipe, 1 Concentric Termination, 1 Aluminum Flex Tube, 1 Silicone Tube (5 ft. length), Gear Clamps, Hose Connection, Cinch Ties <i>NOTE: This kit also requires the purchase of the Direct Vent Conversion Kit, except for GSWT-540H-DV</i>	4" diam.	2SVSHTCKIT43	✓	
		2ZVCK44		✓
Concentric PVC/CPVC Termination - ULC s636 approved	3" diam.	TH-CVPVC33		✓
Isolation Valve Kit - includes pressure relief valve		TK-IV01	✓	✓
Temperature Remote Controller		TK-RE02	Incl.	
		TM-RE40		✓
Multi Unit Controller (up to 20 units)		TM-MC02		✓
Condensate Neutralizer Kit		TH-NT01		✓