



ENERGY STAR® Qualified Atmospheric Vented Gas Water Heaters

The GSW ENERGY STAR® Qualified Atmospheric Vented Gas Water Heater complies with 2010 ENERGY STAR® qualifications and has an impressive .67 energy factor (EF). With an installed flue damper, higher efficiencies can be achieved therefore saving you money.

Flame Guard® patented technology prevents the ignition of flammable vapours from products such as gasoline, paint thinner and solvents. Subjected to over 1,000 tests including lint, dust and oil, butane and endurance burn, the Flame Guard® system is the safest and most proven technology available today.

PRODUCT FEATURES

- Same tank diameter as existing 0.62 EF models
- ENERGY STAR® qualified
- Flue damper for increased EF and performance
- 24 volt gas valve
 - Diagnostic capabilities
 - Monitors damper for increased performance and safety
 - Modular valve for ease of replacement
 - Spark ignition eliminating standing pilot
- Includes a 20 foot 24-volt power cord that can be increased up to 50 feet

LONG-LASTING DEPENDABILITY MEANS YEARS OF ASSURANCE

- Glass-lined flue prevents scaling
- Top mounted heavy duty anode rod for added tank protection
- Robust 1/4" pilot tubing

BENEFITS OF THE FLAME GUARD® SYSTEM

Servicing made simple - saves you time and money

- Combustion chamber is easy to access
- T&P valve is conveniently located at the side of the tank to facilitate piping to a drain or outside the building
- Dependable three-leg design for better leveling and access to flame arrestor



ENERGY STAR® Qualified Atmospheric Vented Gas Water Heaters

Warranty	Models	CAPACITY			BTU Input	RECOVERY @ (100°F/45°C)			Energy Factor	A	B	C	D	Draft Hood Connector (in.)	Approx. Ship Wt. lb/kg
		Imp. Gal	US Gal	Litres		USG/h	IG/h	Litres/h		JACKET DIA. in/cm	Top of Vent in/cm	Top of Heater in/cm	Height to Gas Inlet in/cm		
9	G940S38ES2	33	40	151	38,000	32	27	122	0.67	21/53.24	55.75/141.6	49.1/124.8	12.5/31.75	3 & 4	138/63
9	G940T40ES2	33	40	151	40,000	34	28	128	0.67	19/48.3	66.13/168	59.5/151.1	12.69/32.23	3 & 4	135/61
9	G950S40ES2	42	50	189	40,000	34	28	128	0.68	22.5/57.2	57.25/145.4	50.6/128.6	13.5/34.29	3 & 4	170/77
9	G950T40ES2	42	50	189	40,000	34	28	128	0.68	21/53.34	64.75/164.5	58.1/147.6	12.25/31.12	3 & 4	168/76

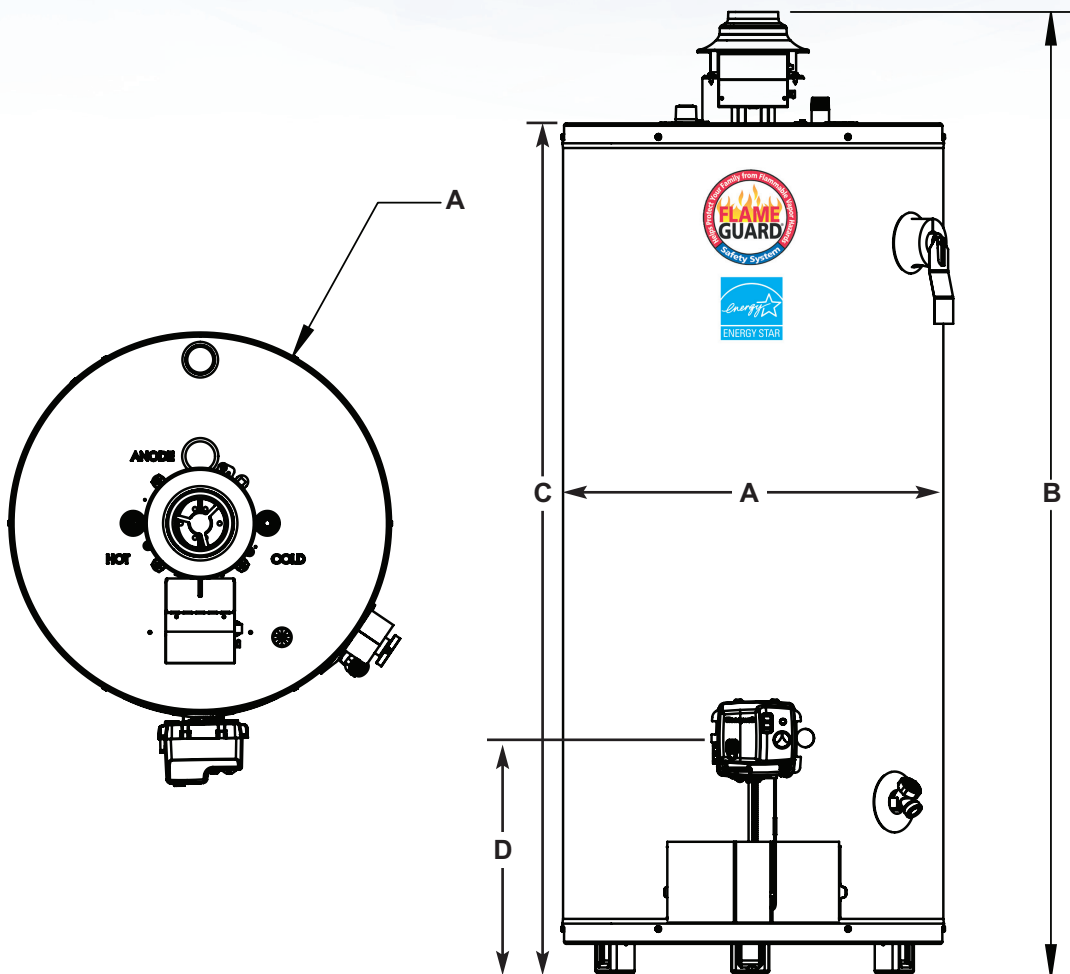

GSW Warranty:

All GSW and John Wood® Water Heaters will be replaced free of charge in the case of tank leakage within the stated warranty period from the date of installation in domestic applications, and one year in commercial applications. All parts supplied are warranted for one year. Warranty does not include labour. Consult owner's manual for complete details.

GSW Water Heating HEAD OFFICE:

599 Hill Street West
 Fergus, ON, Canada N1M 2X1
 Tel: 888-599-2837
 Fax: 519-787-5500
 E-mail: gswinfo@gsw-wh.com
www.gsw-wh.com

